



Fords Close
Bledlow Ridge

www.bb-estateagents.co.uk



bonners & babingtons



This stunning four-bedroom, semi-detached property is situated in the charming and picturesque village of Bledlow Ridge, Buckinghamshire. The property offers a rare opportunity to own a spacious, recently extended home in one of the most desirable locations in the area.

6 Fords Close, Bledlow Ridge, Buckinghamshire, HP14 4AP

- MODERN THROUGHOUT
- THREE RECEPTION ROOMS
- REAR GARDEN WITH PATIO AREA
- PRIVATE DRIVEWAY
- FAMILY BATHROOM AND DOWNSTAIRS SHOWER ROOM
- FOUR DOUBLE BEDROOMS
- LOCAL AMENITIES NEARBY INCLUDING A VILLAGE STORE
- GREAT TRANSPORT LINKS



78 High Street, Princes Risborough, Buckinghamshire, HP27 0AX

01844 343661

www.bb-estateagents.co.uk

Bledlow Ridge

Located in the heart of Bledlow Ridge, this property is ideally situated for those who want to enjoy the best of village life whilst still being within easy reach of local amenities. The village offers a range of excellent pubs and restaurants, as well as a post office and convenience store. The surrounding countryside is also perfect for those who enjoy outdoor pursuits, with plenty of beautiful walks and cycle routes to explore.

Bledlow Ridge is conveniently located just 5 miles from the historic town of Princes Risborough, which offers a range of shopping and leisure facilities, as well as excellent transport links to London and other nearby towns and cities.

Overall, this stunning property offers an exceptional opportunity to own a spacious and beautifully designed home in one of the most desirable locations in Buckinghamshire. With its impressive list of features and enviable location, it is sure to appeal to a wide range of buyers seeking an idyllic rural lifestyle within easy reach of all the amenities and attractions of the surrounding area.



Description

This stunning four-bedroom, semi-detached property is situated in the charming and picturesque village of Bledlow Ridge, Buckinghamshire. The property offers a rare opportunity to own a spacious, recently extended home in one of the most desirable locations in the area.

With four spacious double-bedrooms, three of which have built-in storage space and two modern bathrooms, this property is perfect for families looking for a comfortable and contemporary home.

The ground floor of the property comprises a large and welcoming reception room, offering plenty of space for relaxing and entertaining guests. There are two further reception rooms which are multi-functional, depending on the buyers requirements.

The kitchen is fully equipped with state-of-the-art appliances and features underfloor heating, making it the perfect space for those who love to cook and entertain. The inclusion of a hot water tap and water softener ensures that your water is always of the highest quality. The kitchen benefits from a breakfast bar and has ample room to create a dining area.

The garden is a real feature of the property, offering a beautiful and tranquil space for relaxation and outdoor dining. The patio area is perfect for summer barbecues and socialising with friends and family, whilst the lawned area offers plenty of space for children and pets to play. Outside storage space can be found within a reasonably sized garden shed.

One of the main benefits of this property is the large parking area, which can accommodate up to four cars, making it perfect for those with multiple vehicles or large families.





General Remarks and Stipulations

Tenure

Freehold

Services

Mains gas central heating system, water, electric and drainage.

EPC Rating

D

Local Authority

Wycombe District Council

Post Code

HP14 4AP

Viewing

Strictly by appointment with Bonners & Babingtons

Fixtures and Fittings



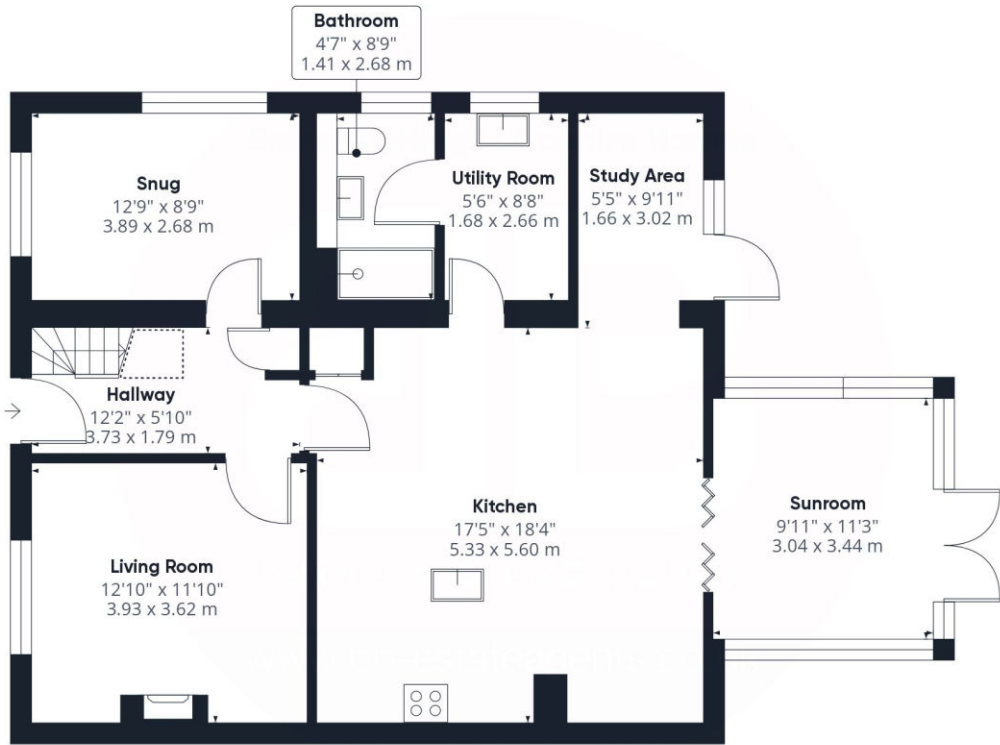

Ground Floor Building 1

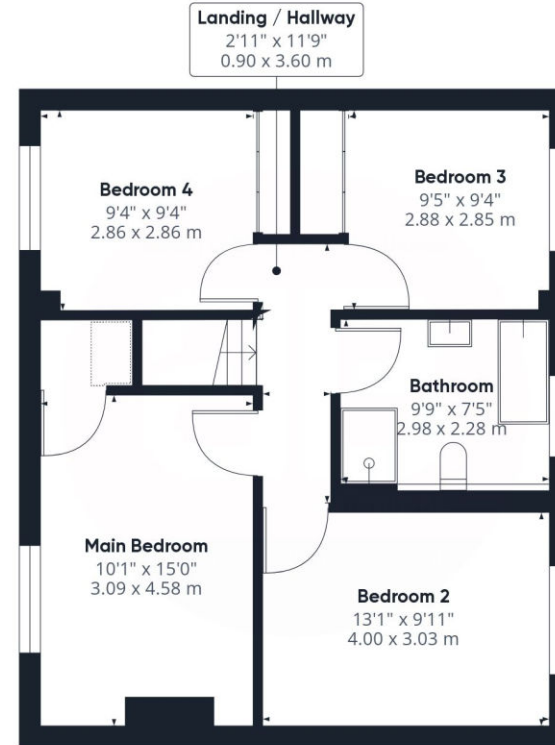

Floor 1 Building 1

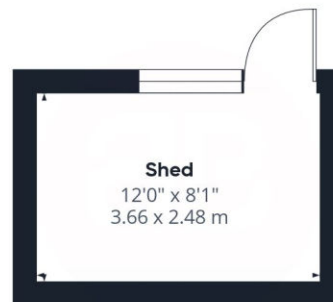

Ground Floor Building 2

Approximate total area⁽¹⁾

1644.41 ft²

152.77 m²

Reduced headroom

7.24 ft²

0.67 m²

(1) Excluding balconies and terraces

⊞ Reduced headroom (below 1.5m/4.92ft)

While every attempt has been made to ensure accuracy, all measurements are approximate, not to scale. This floor plan is for illustrative purposes only.

